

Installation, Commissioning and Maintenance Instructions

– for Horstmann S1xxR Meters and Smart Metering Systems

Issue 1.0 – 2nd December 2009

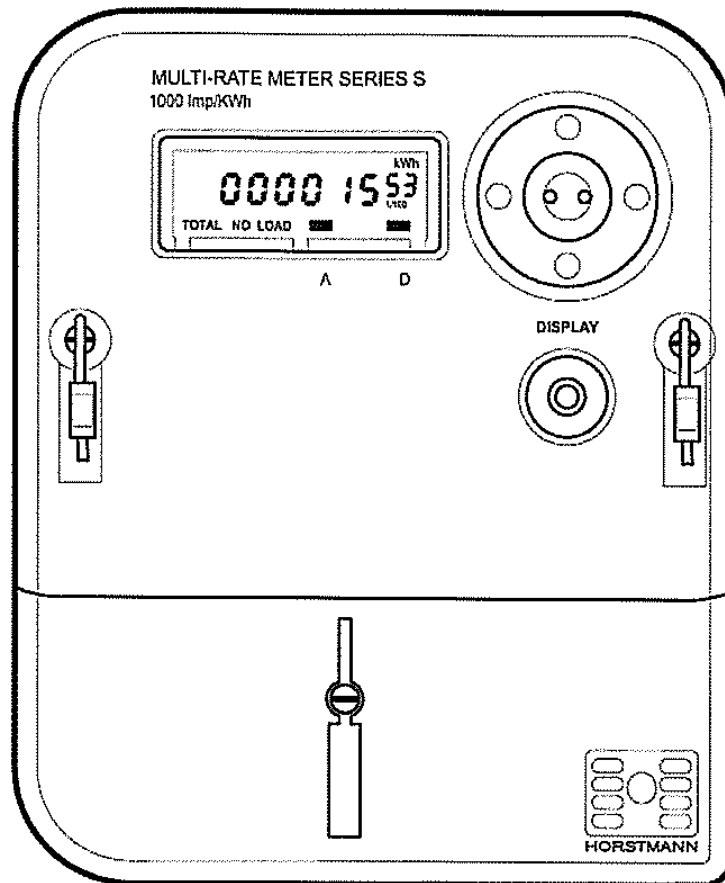

Also covering use with the Horstmann Home Energy Monitor

– and the Technolog Zmart Link Gas Unit.

List of Changes for S1xxR Installation Instructions

1. Document created based on “Installation and Commissioning Instructions SG23R”
Issue 1 .1.

Version	Edited	Date	Checked	Issued
Issue 1.0	MW	2Dec09	BL	2Dec09

Contents

Part 1 – Introduction

1. Background
2. Equipment and Tariff Configurations
3. Safety Considerations

Part 2 – Installation

4. Assessment of the Metering Site
5. Selection of GSM Network and SIM Card
6. Selection of Tariff Configuration
7. Installation of the Metering Equipment

Part 3 – Commissioning

8. Initial Commissioning of the S1xxR Meter in Installer Mode
9. Commissioning an S1xxR Metering Installation
10. Customer Instruction

Part 4 – Maintenance and Servicing

11. Post-Installation Servicing
12. Change of Home Energy Monitor
13. Change of Gas Meter or Zmart Link
14. Removal of Metering Equipment

ANNEXES

- A. Configuration Diagrams for S1xxR-Series Meters
- B. Meter Display Sequences
- C. Home Energy Monitor Displays
- D. Overview of the Home Energy Monitor
- E. Signal Strength Survey for S1xxR Meters
- F. Advanced Functions for Z-Wave Certified Meter

Part 1 - Introduction

1. Background

Caution – Restricted Use: *These Instructions for the S1xxR meters and any associated smart metering equipment are only intended for use by Accredited Electricity Meter Operators and Registered Gas Meter Workers, operating under the requisite industry agreements and practices and regulations. The equipment is not intended for installation and commissioning by any other persons, and Horstmann will not be responsible for the consequences of any such use or attempted use or misuse of these products and instructions.*

S1xxR is the type designation for a range of Z-Wave S-series single element electricity meters that run on a 230V 50Hz mains supply, and the xx denotes a hardware configuration for whether the meter also carries a 100 Amp and/or a 2 Amp switch. The S123R is a full hardware specification S-series Z-Wave meter, and has the full part number S123xxxR, where the additional xxx define the customer configuration such as tariff scheme and a customer identifier. The Z-Wave user functionality and the schedule of Z-Wave message transmissions are identical for all S1xxR meters, and neither the 100 A or 2 A switch is Z-Wave controlled.

The Horstmann S1xxR Smart Meters form part of a smart metering system that can provide residential customers with detailed energy data for electricity and gas usage. The S1xxR can support the Zmart Link gas mini-logger (on a suitable U6/R5 metric or Imperial gas meter) for collecting Gas consumption, and the Horstmann Home Energy Monitor (HEM) for displaying Electricity and Gas consumption. The products may be used to study how various methods of providing better information to residential customers about their recent energy consumption can give rise to better understanding of energy usage and longer-term reductions in energy consumption.

The S1xxR range of meters is based on the following general assumptions:

- a) All meters will be for residential single-phase two-wire electricity supplies, for import of energy only (the HEM does not support export of energy).
- b) No prepayment-metered customers will be involved.
- c) No two-meter electric heating tariffs will be involved.
- d) All gas meters involved will be U6/R5 compatible metric or Imperial meters; (1 pulse per 0.01 m³, or 1 pulse per cu ft).
- e) All electricity meters from the factory will be delivered with a basic “default” single-rate tariff configuration (SSC 393).
- f) Multi-rate tariff configurations may be loaded via local opto port.
- g) The HEMs are delivered without any site-specific parameters loaded. The HEM picks up the tariff structure and times from the associated electricity meter. The electricity (and gas) prices/rates are to be set on the HEM during (or prior to) the installation visit.

The gas meter reading on the HEM includes an allowance for the initial offset reading when a new Zmart Link unit is installed.

2. Equipment and Tariff Configurations

These are the S1xxR meters available:

S100xxxR:	100 Amp metered only
S111xxxR:	100 Amp metered with 100 Amp Contactor
S114xxxR:	100 Amp metered with 2 Amp Relay
S115xxxR:	100 Amp metered with 2 Amp Relay (Volt Free)
S116xxxR:	100 Amp metered with 2 Amp Relay (1200 VA)
S117xxxR:	100 Amp metered with 2 Amp Relay (1200 VA & Volt Free)
S122xxxR:	100 Amp metered with 100 Amp Contactor & 2 Amp Relay
S123xxxR:	100 Amp metered with 100 Amp Contactor & 2 Amp Relay (Volt Free)

Configuration A = Electricity Meter Only.

Configuration B = Electricity Meter and Gas.

Configuration C = Electricity Meter and Monitor Only.

Configuration D = Electricity Meter, Gas and Monitor.

See Annex A for diagrammatic representations.

For S1xxR meters configurations A and B are of no use to the customer, unless a product from another OEM is used to request electricity and gas from the meter.

All meters can support tariffs of up to 4 rates.

3. Safety Considerations

These Instructions for the S1xxR meters and any associated smart metering equipment are only intended for use by Accredited Electricity Meter Operators and Registered Gas Meter Workers, operating under the requisite industry agreements and practices and regulations.

The equipment is not intended for installation and commissioning by any other persons, and Horstmann will not be responsible for the consequences of any such use or attempted use or misuse of these products and instructions.

The relevant electrical safety regulations and practices must be followed at all stages of installation and commissioning and subsequent maintenance visits.

Where applicable the relevant gas safety regulations and practices must also be followed at all stages of installation and commissioning and subsequent maintenance visits.

The equipment is not designed or intended for user servicing or repairs. Where a unit is shown to be faulty it should be returned to Horstmann for service or repair and re-certification.

Part 2 - Installation

4. Assessment of the Metering Site

Prior to the visit the following site information is to be determined, including the gas-related information for sites involving the S1xxR meter:

- Site address and MPAN (and MPRN).
- Supplier and electricity tariff type (and SSC), and Configuration.
- Electricity (and gas) tariff prices/rates, after discounts, with/without VAT (for the HEM).
- Any electricity load switching requirements.
- Arrangements for change of existing gas meter (including from semi-concealed type).

On arrival at a site involving the S1xxR meter a short survey is also needed to ensure that satisfactory wireless operation at 868 MHz can be achieved for each of the two radio paths: Meter to HEM, and Meter to Zmart Link (if dual-fuel). See Annex E for details.

The results of this short survey will indicate whether it is likely to be practicable for the installation of the HEM to proceed (also for the Zmart Link gas unit on dual-fuel sites).

5. Selection of GSM Network and SIM Card

Not Applicable.

6. Selection of Tariff Configuration

The following tariff programmes may be programmed into the meters at the meter test station or depot. The SSC references include those that have traditionally been used.

- General/Standard Tariff – single-rate – SSC 393.
Normal Rate 1 operates continuously.
- Economy 7 – 2-rate – SSC 244.
Low Rate 2 from 00.00 to 07.00 GMT-only, all days; switches A and D are closed.
Normal Rate 1 at all other times.
Note: other E7 times and split time blocks may arise (SSCs 151, 153, 373, 378).
- Economy 10 – 2-rate – SSC 935.
Low Rate 2 from 00.00 to 05.00, 13.00 to 16.00, 20.00 to 22.00, GMT-only, all days.
Normal Rate 1 at all other times.
- TOU Trials Tariff – 4-rate example
Peak Rate 4 from 16.00 to 19.30, Monday to Friday only, 1 Nov to 1 Mar, GMT/BST.
Evening Rate 3 from 19.30 to 24.00, all days.
Night Rate 2 from 00.00 to 07.30, all days.
Day Rate 1 at all other times.

Details of the suggested arrangements and tariff configurations are given in Annex A.

7. Installation of the Metering Equipment

Installation of S1xxR Smart Meters

The accredited Meter Operator will replace the customer's existing electricity meter by the selected meter in accordance with the relevant regulations and codes of practice. Annex A gives an indication of the various arrangements that are expected to be found, but the installation is the responsibility of the appointed metering services organisation.

Note: Economy 7 sites are unlikely to involve gas supplies and metering, so only configurations A and C are then applicable. Load switching via the 100 A switched output may be used on some E7 sites (using terminal 5 on suitable meters).

Installation of the Home Energy Monitor

For installations where a HEM is involved (configurations C and D) the HEM may initially be plugged into a convenient 13 A socket near the electricity meter and made ready for commissioning – see Section 9.1.

Where an installation with gas but no HEM is involved (Configuration B) then a temporary “test” HEM may initially be plugged into a convenient 13 A socket near the electricity meter and made ready for commissioning – see Section 9.1. This is used to check the commissioning of the Zmart Link gas unit; then the test HEM is deleted from the meter wireless network (in Installer mode) and removed from site.

After commissioning has progressed for configurations C and D (see section 9.3) the HEM should be installed in an appropriate permanent location (section 9.5) and the customer instructed in its use (section 10).

Installation of the Gas Meter and Zmart Link Unit

Where gas metering is also involved (configurations B and D) the accredited Meter Worker will usually replace the customer’s existing gas meter by a U6/R5 compatible metric or Imperial gas meter in accordance with the relevant regulations and codes of practice. Annex A gives an indication of the various arrangements that are expected to be found, but the installation is the responsibility of the appointed metering services organisation.

The Zmart Link unit will be connected to the gas meter’s R5 pulse output during the commissioning process, and only after this can it be fixed in a secure manner near to the gas meter - see section 9.3(c) and Annex E2.

Part 3 - Commissioning

8. Initial Commissioning of the S1xxR Meter in Installer Mode

Initial checks and powering up are similar to those for a normal multi-rate credit meter.

On power up the S1xxR meter enters Installer Mode for the first 5 minutes – see Annex B for operation and the Installer display list. Note: Learn Mode and Protocol Reset may also need to be added to the display list for some Zwave network configurations – see Annex F.

The meter starts up in the Load Switch Exercise mode. If the blue button is held down for 2 seconds it switches to the Installer Display List. Each time the button is held down for 2 seconds the meter alternates between these two facilities, until the 5-minute Installer Mode period expires.

Use the Installer Display List check that the meter is showing the correct registers, time, date, and tariff reference. With the meter the Installer List includes up to 5 extra items at the end for Zwave network operation – these are used where a Zmart Link unit and/or HEM are installed (see 9.2 and 9.3).

Note: With Economy 7 tariffs the 100 A switched output may be used on some sites (switch D out via terminal 5 on suitable meters). Use the Load Switch Exercise facility to check that switch D is switching the heating circuit – in this mode each short press of the button changes the state of switch D and then A, as shown by the 2 icon bars along the lower edge of the meter display. Wait for 6 seconds between each press in this mode.

If the meter display flashes “all 8’s” every 5-seconds then the meter should be returned to the meter test station.

For an S1xxR meter with a HEM and/or Zmart Link gas unit then go to 9.1, 9.2, and 9.3.

9. Commissioning of an S1xxR Meter Installation

9.1 General

Assumptions for using this section:

- An S1xxR electricity meter with appropriate tariff configuration has already been selected and installed and prepared for commissioning as in 7 and 8 above.
- A U6/R5 metric gas meter has been installed and is ready for use (for Configuration B or D).
- A Zmart Link gas unit is also available (initially held at the electricity meter position).
- A HEM is available and initially plugged into a convenient 13 A socket (for Configuration C or D). A temporary Test HEM is used for Configuration B – see 7.2.

Also for S1xxR sites a short survey has already been completed successfully to assess wireless operation at 868 MHz for each radio path – the meter to HEM location, and meter to Zmart Link location if a dual-fuel site. See 4 above and Annex E, then decide how to proceed with the installation.

This section deals with the various equipment configurations:

Configuration A – Go straight to 9.4.

Configuration B – Go to 9.2 (Test HEM), then 9.3, then 9.4.

Configuration C – Go to 9.2 then 9.4 then 9.5.

Configuration D – Go to 9.2 then 9.3 then 9.4 then 9.5.

The certified electricity meter is capable of including any z-wave compliant unit to its network. The procedure for the meter to include any device follows the inclusion procedure detailed in section 9.2 or 9.3.

The certified electricity meter is capable of excluding any z-wave compliant unit from its network. The procedure for the meter to exclude any device follows the exclusion procedure detailed in section 12.2 or 13.2.

The certified electricity meter can become part of another z-wave compliant network, and be removed from it through use of the Learn Mode selection detailed in Annex F.

9.2 Adding a Home Energy Monitor (HEM)

(with configurations C and D, or as a temporary Test HEM with configuration B).

HEM – Include Process

a) Preparation

- The HEM may be plugged into a 13 A socket near the meter initially, if this is more convenient than its final position (see also 7.2 and Annex E2).
- The meter should now be powered up so it is in Installer Mode for the first 5 minutes.
- The HEM should be ready for inclusion in the meter's Zwave network (flap open).

b) Inclusion

The HEM can be included to any z-wave compliant network, but for the purposes of this document the meter is the z-wave controller. Put the meter into network include mode as follows:

1. Press and hold the blue front button for 2 seconds (enters Installer Displays).
2. Cycle through each display menu item with single presses until the display shows "INC NODE". Do not press the blue button again unless repeating the process.
3. Wait 5 seconds and the display will show "oooo" for one second.
4. Display will now show either "SENT" or "FAIL" (if "FAIL" wait for 30 seconds and retry the process from the second bullet - the routing circuit was busy). Note: If it is still not possible to obtain the "SENT" message then the meter should be powered down briefly and powered up again – then wait for 2 minutes before repeating the inclusion process.
5. The Zwave module is now in the INCLUDE state for the next 2 minutes.

The procedure on the HEM to join any z-wave compliant network (assuming a controller is present in include mode, and in this case is the meter) is:

1. Press the green button on the HEM (i.e. under the flap).
2. Choose the menu item "COMMISSIONING", using the Plus and Minus buttons and press the Enter button.
3. Choose the menu item "NETWORK SUPPORT" and press the Enter button.
4. Choose the menu item "SEND FRAME" and press the Enter button.
5. The HEM will display "JOINED NETWORK" (Pass) or "NO CHANGE" (i.e. failure or HEM is already included, wait and repeat).
6. In the case of a successful include press the green button to return to the main display. Close the flap.
7. In the case of a fail, if the HEM is not already included repeat the procedure from step 2, but ensure the controller is in include mode.

During the process the meter display should briefly show the message "PASS INC" in which case the procedure is complete, else the meter will display "FAIL" in which case wait for a 30 seconds period to elapse and repeat this process from the second bullet point (still within the 5-minute installer mode period). Note: It is important to step around the 15 steps in the Installer Display sequence to arrive back at the "INC NODE" display to re-activate the INCLUDE state if a repeat attempt is needed.

Before moving the HEM to a final position for the customer (in section 9.5 below) and while the meter and HEM are still powered up check that the HEM is operating properly. As the meter sends the reports supported by the HEM, immediately after inclusion, check that the main display on the HEM shows the correct time and date (in GMT/BST clock time), and

that a Power Now update occurs every 15 seconds. If the HEM was commissioned in its final position then carry out this check now.

c) Completion

- If the S1xxR installation also includes a Zmart Link gas unit fitted to a U6/R5 metric gas meter, then that unit should next be included on to the electricity meter's Zwave network, the Zmart Link completion checks should also be made, and the GAS OFFSET value should be entered into the HEM – all as described in 9.3 below.
- If the electricity rates (prices) and the gas rate have not been entered earlier or prior to the visit, then set the electricity rate(s) and any gas rate now – see Annex C Figures 2 and 3 and Annex D. The settings may be checked from the main screen by pressing the blank pushbutton. N.B: These settings may be input at any convenient time.
- When the HEM is set up ready for use it can be unplugged and moved to the chosen location suitable for the customer, typically in the kitchen, hall, or lounge (see 9.5). Satisfactory wireless reception at the new location should be checked by observing the 15-second updates to the Power Now indication on the HEM's main display.
- Finally, the customer should be given a brief overview and instructions on the use of the HEM (see section 10).

9.3 Adding a Zmart Link Gas Unit

(with configurations B and D)

a) Preparation for Zmart Link Include Process

- A U6/R5 metric gas meter is already installed and ready for use.
- The HEM has already been commissioned (see 9.2) as it is used for some of the completion checks below. The HEM may initially be plugged into a convenient 13 A socket near the meter for this work, before moving it to its final location – see Annex E3. It may be a temporary Test HEM for configuration B.
- The Zmart Link gas unit should be held near to the electricity meter for the Include process.
- The meter should now be powered up so it is in Installer Mode for the first 5 minutes.
- The Zmart Link unit should be ready for inclusion in the meter's Zwave network (a magnet should be at hand to initiate the Zmart Link unit).

b) Inclusion (Zmart Link is held close to S1xxR meter)

The ZMART can be included to any z-wave compliant network, but for the purposes of this document the meter is the z-wave controller. Put the meter into network include mode as follows:

1. Press and hold the blue front button for 2 seconds (enters Installer Displays).
2. Cycle through each display menu item with single presses until the display shows "INC NODE". Do not press the blue button again unless repeating the process.
3. Wait 5 seconds and the display will show "oooo" for one second.
4. Display will now show either "SENT" or "FAIL" (if "FAIL" wait for 30 seconds and retry the process from the second bullet).
5. The Zwave module is now in the INCLUDE state for the next 2 minutes.

The procedure on the ZMART to join any z-wave compliant network (assuming a controller is present in include mode, and in this case is the meter) is:

1. Swipe the unit's front panel with a magnet once, a blue LED should flash, if no flash is seen swipe again.

Note: The Zmart Link's internal total register will start incrementing from 0 at this point.

The meter display should briefly show the message "PASS INC" in which case the Include process is complete, else the meter will display "FAIL" in which case wait 30 seconds and repeat this process from the second bullet point (still within the 5-minute installer mode period). Note: It is important to step around the 15 steps in the Installer Display sequence to arrive back at the "INC NODE" display to re-activate the INCLUDE state in the meter.

If it was not possible to obtain PASS in this last step then exclude the Zmart Link (see 13.2b) and start this inclusion process again.

c) Completion

- After completing the Include process the Zmart Link unit should be taken to the gas meter, connected to the R5 interface, and fixed in position securely – see Annex E2.
- The current reading of the gas meter (at the time that the new Zmart Link unit was connected) should also be noted, in addition to what may be required under gas metering procedures and MAMCOP – see 9.4.
- If a HEM is also included as part of the smart metering installation (and has been set for a metric or Imperial gas meter, as appropriate), then set the HEM's GAS OFFSET value to the initial 5-digit reading of the gas meter index (in whole m³ or x 100 cu ft), i.e. the reading at the time that the new Zmart Link unit was connected to the gas meter. Refer to (d) below. This setting may also be done later, i.e. after the S1xxR's installer mode period has expired.
- It could be 30 minutes or so before the next automatic gas data transfer will be discernible on the HEM [under GAS – ENERGY – Gas Used]. Instead check the wireless communications with the Zmart Link in its installed position by swiping a MAGNET over the front face of the Zmart Link (the Zmart's BLUE LED should flash). Then go to the HEM and check that the Gas Used screen [Total at Time and Date] has then updated successfully – it is necessary to re-select via [GAS – ENERGY – Gas Used] to refresh the HEM display. If some gas use is taking place it should be possible to see a small increase in the Gas Used Total (00000.00 m³ reading) on the HEM.

This gas data check may be done with the HEM either in an initial temporary position, or in its final location. It should also be done where a Test HEM is used (configuration B); after this delete the Test HEM from the S1xxR meter and remove it (see 13.2b).

d) Setting the GAS OFFSET Value on the HEM (if a Zmart Link gas unit is included)

- (HEM) Press the green button on the HEM (i.e. under the flap).
- (HEM) Choose the menu item "COMMISSIONING", using the Plus and Minus buttons and press the Enter button.
- (HEM) Choose the menu item "GAS OFFSET VALUE" and press the Enter button.
- (HEM) Input the gas offset value using the Plus, Minus and Enter buttons (one digit at a time). This is the initial 5-digit reading of the gas meter index (in whole m³ or x 100 cu ft), at the time that a new Zmart Link unit is connected to the gas meter.
- (HEM) Press the green button to return to the main display. Close the flap.

9.4 Meter Data Retrieval Commissioning Process

Not Applicable.

Notes:

1. Any Test HEM may be disconnected now.
2. The meter operator completes the job record.

9.5 Finding an Appropriate Location for the HEM in the Home

If the HEM was initially commissioned in a temporary position it should now be moved to its final position (preferred by the customer as far as possible). The location for the HEM should already have been chosen to give satisfactory radio reception as in 4 and Annex E3 – this should normally be within 6 m (20 feet) of the electricity meter position where transmission through building walls is involved. Check that the Power Now value shown on the main display is normally updated from the meter every 15 s. Poor reception is shown after 2 or more minutes by the NO COMMS indication appearing on the main display – see 10.. Also check that the main display on the HEM shows the correct time and date (in GMT/BST clock time), and that the correct number of rates for the tariff in the S1xxR meter are shown on the HEM's Energy used Today screen [Normal = Rate 1]. In normal operation the two red/orange/green consumption indicators light when the HEM is showing the main display; red does not mean the HEM is faulty – see Annex D.

In addition to ensuring that satisfactory radio reception is achieved the following practical points need to be considered when selecting a suitable location for the Home Energy Monitor, as covered in the initial short survey of the premises in section 4 and Annex E3:

- Indoors only, in a frequently used place (lounge, hall, kitchen...).
- Near to a suitable 13 A socket (the HEM cable is 1.1 m long).
- On a work surface (not at low level – keep away from small children).
- Where it is easily accessible frequently, but is unlikely to be dislodged or dropped.
- Away from pouring water or steam – taps, sinks, kettles.
- Not likely to be in direct sunlight for lengthy periods.
- Not close to strong sources of heat.
- Not covered up at all, nor in a cupboard or drawer.
- Not on vibrating equipment (washing machines, spin dryers, microwave ovens).

The unit must remain plugged into the (dedicated) 13 A socket at all times – the red notice on the plug confirming this should be pointed out to the customer as part of the customer instructions given in 10 below.

10. Customer Instruction

For the S1xxR meter alone (configuration A) or the S1xxR meter with only the Zmart Link gas unit included (configuration B) there is little customer instruction required during the installation visit. Once the meter has been powered up for longer than the installer display mode (5 minutes) then the first press of the meter's pushbutton results in the present instantaneous power being displayed in Watts (e.g. P 000405 is 405 Watts), and this facility may help some users discover and respond to some aspects of their electricity usage.

When the HEM is used with the S1xxR meter (in configurations C or D) then this instantaneous power value is still available on the meter. The same value is transferred to the HEM every 15 s and drives the power bar on the main HEM “Power Now” screen. The HEM’s “Power Now” screen includes the minimum and maximum values of instantaneous power that have occurred since last midnight, and the size of the minimum value is very important for energy saving. For instance if the minimum daily power does not usually fall below 0.10 kW or 100 Watts then this indicates that there are some devices always in use that over one year would draw power equivalent to approximately 25% of average domestic electricity consumption (400 W average or 3600 kWh per year). The user should be advised to look into the nature of their minimum load (or “leakage”) regularly and seek to reduce it. See Annexes C and D for operation of the HEM.

When the HEM is commissioned it will only show the “Power Now” kilowatt value initially, and the daily, weekly, and 28-day period screens on the display will show zero data. Over the next few hours and days the usage data for the displays will gradually build up, and after 28 days nearly all the displays will be populated. This encourages a continuous process of discovery by the energy users, but also means that only limited instruction can be given to the users at the time of installation. The user should be made aware of this characteristic and encouraged to look at the additional screens regularly. There are numerous additional screens for electricity and gas usage - the cost indications of energy consumed (using the £ buttons) are also likely to be useful for most customers as data builds up, once the energy rates (prices) have been set.

The unit must remain plugged into the chosen (dedicated) 13 A socket at all times – the red notice on the plug confirming this should be pointed out to the customer.

The “Power Now” updates on the main screen should be pointed out to the customer, noting that if this changes to “NO COMMS” persistently then the energy supplier should be informed. See the figure below.

Finally, the customer should be made aware that the HEM only works in conjunction with the electricity meter installed in their premises, and will not work if taken to another home.

No Communications Received for Past 3 Minutes

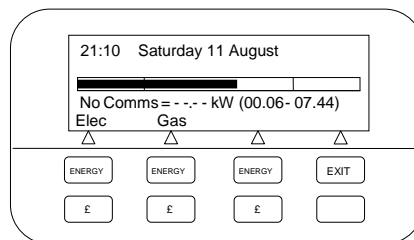

Part 4 – Maintenance and Servicing

11. Post-Installation Servicing

There are no regular maintenance requirements during normal operation and use for the S1xxR meters, Zmart Link gas unit, and HEM. However the price settings in the HEM will

require changing if the electricity and/or gas prices change see Annex C Figure 3 and Annex D – this may be carried out by the customer with the User Guide.

The S1xxR meter, Zmart Link gas unit, and HEM all include internal lithium batteries that are sufficient to cover the life of the unit in normal operation.

None of the equipment is designed or intended for user servicing or repairs. None of the units should be dismantled and then returned to use. Where a unit is shown to be faulty it should be returned to Horstmann for service or repair and any re-certification.

Fault-finding methods will be established partly from experience with the equipment. Procedures for changing a HEM or Zmart Link gas unit are given in 12 and 13 below.

12. Change of Home Energy Monitor

12.1 General

- **(Configuration C)** If the HEM has to be replaced for any reason then follow the Exclude process below, and then add a new HEM as in section 9. If the existing HEM has failed and cannot be excluded from the Zwave network (e.g. its internal power supply has failed) then it is permissible to take the faulty HEM away and include a new second HEM onto the Zwave network.
- **(Configuration D)** The HEM may be replaced in the same way as above, but since a Zmart Link unit is also included as part of the installation then it may not be straightforward to establish what the gas offset value for the new HEM with existing Zmart Link unit should now be (apart from using trial and error). The relevant gas offset reading will have been set in the old HEM - but may no longer be accessible.

In this situation the existing Zmart Link unit should rather be replaced by a new Zmart Link unit; then the new HEM should be included as in section 9. New energy data in the HEM will then gradually be built up. The new GAS OFFSET value in the HEM should be set to the gas meter reading at the date/time of change to the new Zmart Link unit - see Section 9. The current reading of the gas meter should be recorded, in addition to what may be required under gas metering procedures and MAMCOP – see 9.4.

12.2 HEM – Exclude Process

a) Preparation

- The existing HEM should be plugged into a 13 A socket near the meter, if this is more convenient.
- The meter should now be powered up so it is in Installer Mode for the first 5 minutes.
- The HEM should be ready for exclusion from the meter's Zwave network (flap open).

b) Exclusion

The HEM can be excluded from any z-wave compliant network, but for the purposes of this document the meter is the z-wave controller. Put the meter into network exclude mode as follows:

1. Press and hold the blue front button for 2 seconds (enters Installer Displays).

2. Cycle through each display menu item with single presses until the display shows “DEL NODE”. Do not press the blue button again unless repeating the process.
3. Wait 5 seconds and the display will show “oooo” for one second.
4. Display will now show either “SENT” or “FAIL” (if “FAIL” wait 30 seconds and retry the process from the second bullet - the routing circuit was busy).
5. The meter’s Zwave module is now in the EXCLUDE state for the next 2 minutes.

The procedure on the HEM to leave any z-wave compliant network (assuming a controller is present in exclude mode, and in this case is the meter) is:

1. Press the green button on the HEM (i.e. under the flap).
2. Choose the menu item “COMMISSIONING”, using the Plus and Minus buttons and press the Enter button.
3. Choose the menu item “NETWORK SUPPORT” and press the Enter button.
4. Choose the menu item “SEND FRAME” and press the Enter button.
5. The HEM will display “LEFT NETWORK” (Pass) or “NO CHANGE” (i.e. failure or HEM is already excluded).
6. Press the green button to return to the main display. Close the flap.

During the process the meter display should briefly show the message “PASS DEL” in which case the procedure is complete, else the meter will display “FAIL” in which case wait 30 seconds and repeat this process from the second bullet point (still within the 5-minute installer mode period).

c) Completion

- Either the old HEM unit is to be removed permanently, or a replacement HEM unit is now to be fitted. A replacement HEM may normally be fitted without changing the electricity meter or the Zmart Link gas unit (if fitted).
- If a replacement HEM unit is now to be fitted, follow the “HEM – Include Process” at section 9 above. The replacement HEM will gradually build up new stored energy data over the coming days, weeks, and 28-day period.

Note 1: If the existing HEM has failed and cannot be excluded from the Z-wave network (e.g. its internal power supply has failed) then it is permissible to take the faulty HEM away and include a new second HEM onto the Zwave network.

Note 2: If an excluded HEM is subsequently included into the Zwave network of a meter then its internal stored data for the past 28 days energy usage will be reset to zeroes. New energy data for the metering installation that the HEM is now included in will gradually be built up.

Note 3: If there appears to be a permanent difficulty with logging HEM units and/or Zmart Link units on or off the electricity meter’s Zwave network then it may be necessary to change out the meter as well as the other Zwave units to recover normal operation. In this case the new units will need to be included onto the Zwave network of the new electricity meter and new energy data in the HEM will gradually be built up. The GAS OFFSET value should be entered into the new HEM based on the current reading on the existing gas meter. This will involve carrying out the overall Installation and Commissioning processes again.

13. Change of Gas Meter or Zmart Link

13.1 Change of Gas Meter

- **(Configuration B)** If the gas meter has to be replaced for any reason then the existing Zmart Link unit may be connected to the new gas meter. The current readings of the old and new gas meters and the date/time of the meter change should also then be recorded, in addition to what may be required under gas metering procedures and MAMCOP – see 9.4. This assumes that no HEM is involved (configuration B only).
- **(Configuration D)** If a HEM is also included as part of the installation then it will not be straightforward to establish what the gas offset value for the existing HEM plus Zmart Link unit should now be (apart from using trial and error). In this situation the existing Zmart Link unit should rather be replaced by a new Zmart Link unit; the HEM should be excluded and then included again. New energy data in the HEM will then gradually be built up. The new GAS OFFSET value in the HEM should be set to the new gas meter reading at the date/time of change to the new Zmart Link unit - see 9. The current reading of the old and new gas meters and the date/time of change of the replacement Zmart Link unit should also be recorded, in addition to what may be required under gas metering procedures and MAMCOP – see 9.4.
- If the gas meter is to remain but the Zmart Link unit is to be replaced then refer to section 13.2 below.

13.2 Change of Zmart Link Unit

Zmart Link - Exclude Process

a) Preparation

- Before carrying out the Exclusion process the Zmart Link unit should be disconnected from the R5 interface, removed from the gas meter position, and taken to the electricity meter position.
- The Zmart Link gas unit should be held near to the electricity meter for the Exclude process.
- The meter should now be powered up so it is in Installer Mode for the first 5 minutes.
- The Zmart Link unit should be ready for Exclusion from the meter's Zwave network (a magnet should be at hand to initiate the Zmart Link unit).

b) Exclusion

The ZMART can be excluded from any z-wave compliant network, but for the purposes of this document the meter is the z-wave controller. Put the meter into network exclude mode as follows:

1. Press and hold the front button for 2 seconds (enters Installer Displays).
2. Cycle through each display menu item with single presses until the display shows "DEL NODE". Do not press the blue button again unless repeating the process.
3. Wait 5 seconds and the display will show "oooo" for one second.
4. Display will now show either "SENT" or "FAIL" (if "FAIL" wait 30 seconds and retry the process from the second bullet - the routing circuit was busy).
5. The Zwave module is now in the EXCLUDE state for the next 2 minutes.

The procedure on the ZMART to leave any z-wave compliant network (assuming a controller is present in exclude mode, and in this case is the meter) is:

1. Swipe the front panel with a magnet once, a blue LED should flash, if no flash is seen swipe again.

The meter display should briefly show the message “PASS DEL” in which case the procedure is complete, else the meter will display “FAIL” in which case wait 30 seconds and repeat this process from the second bullet point.

c) Completion

- Either the old Zmart Link unit is to be removed permanently, or a replacement Zmart Link unit is now to be fitted. In the first case the current reading of the gas meter should also be recorded, in addition to what may be required under gas metering procedures and MAMCOP.
- If a replacement Zmart Link unit is now to be fitted (configurations B or D), follow the “Zmart Link - Include Process” as in Section 9 above. It is recommended that a new Zmart Link unit is used as the replacement, not an already-used-and-excluded unit. For configuration B the use of a temporary Test HEM is relevant – see 7.4 and 9.3.
- The current reading of the gas meter and the date/time of change of the replacement Zmart Link unit should be noted, in addition to what may be required under gas metering procedures and MAMCOP.
- If the installation also includes a HEM (configuration D) it is recommended that the HEM should be excluded and then included again during the change of the Zmart Link unit. This will reset the HEMs internal storage of energy usage data to zeroes, preventing confusion arising from old and new Zmart Link gas data. New energy data for the smart metering installation that the HEM is now included in will gradually be built up. Set the GAS OFFSET value in the HEM to the gas meter reading at the date/time of change of the replacement Zmart Link unit - see 9.

Note 1: If an already-used-and-since-excluded Zmart Link unit is subsequently included into the Zwave network of an electricity meter (configuration B) then it will output the new gas usage data to the electricity meter, which will continue to record new half-hour data into its gas recording channel. The current reading of the gas meter and the date/time of change of the replacement Zmart Link unit should also be noted, in addition to what may be required under gas metering procedures and MAMCOP.

Note 2: If under Note 1 above an existing HEM is also in use (configuration D) it will not be straightforward to establish what the gas offset value for the HEM should now be (apart from using trial and error). In such situations a failed Zmart Link unit should rather be replaced by a new Zmart Link unit; the HEM should be excluded and then included again. In this case new energy data in the HEM will gradually be built up. Set the GAS OFFSET value in the HEM to the gas meter reading at the date/time of change of the replacement Zmart Link unit - see section 9.3(d).

Note 3: If there appears to be a permanent difficulty with logging Zmart Link units and/or HEM units on or off the electricity meter’s Zwave network then it may be necessary to change out the electricity meter as well as the other units to recover normal operation. In this case new energy data in the new HEM will gradually be built up.

14. Removal of Metering Equipment

Where the smart metering equipment is permanently removed from a premises (e.g. due to Change of Supplier) then notification of the site and meters involved and the date of removal should be recorded.

ANNEX A – Configuration Diagrams for S1xxR-Series Meters

Note: Meters below are shown with both switches fitted = S123R

S1xxR Meter – no Switched Load (A1)

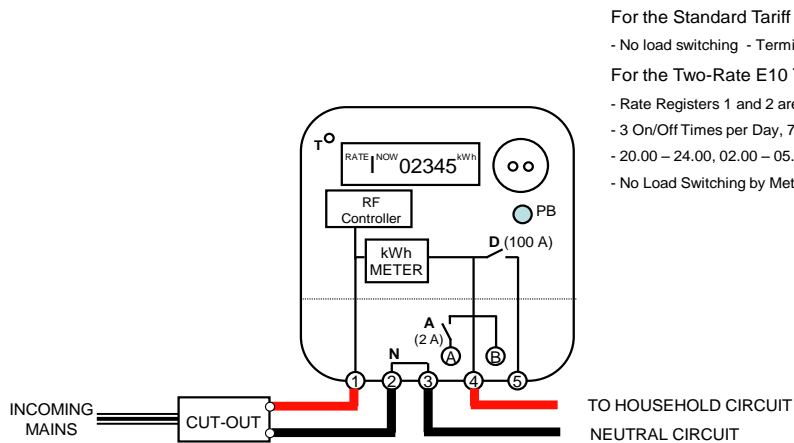

S1xxR BL 2Dec09

For the Standard Tariff (Single-Rate):

- No load switching - Terminal 5 is bunged.

For the Two-Rate E10 Tariff:

- Rate Registers 1 and 2 are Normal and Low.
- 3 On/Off Times per Day, 7 Days, GMT-only (SSC 935).
- 20.00 – 24.00, 02.00 – 05.00, 14.00 – 16.00 GMT.
- No Load Switching by Meter – Terminal 5 is bunged.

S1xxR Meter – with Switched Load (A2)

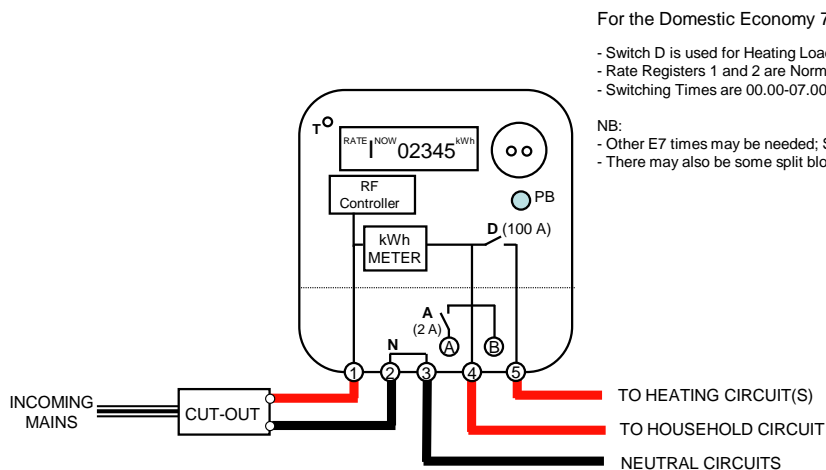

S1xxR BL 2Dec09

For the Domestic Economy 7h Tariff:

- Switch D is used for Heating Loads..
- Rate Registers 1 and 2 are Normal and Low.
- Switching Times are 00.00-07.00, 7 days, GMT (SSC 244).

NB:

- Other E7 times may be needed; SSC 153, 01.00 – 08.00h.
- There may also be some split block E7 tariffs, (SSC 373).

S1xxR Meter – with Gas Meter (B)

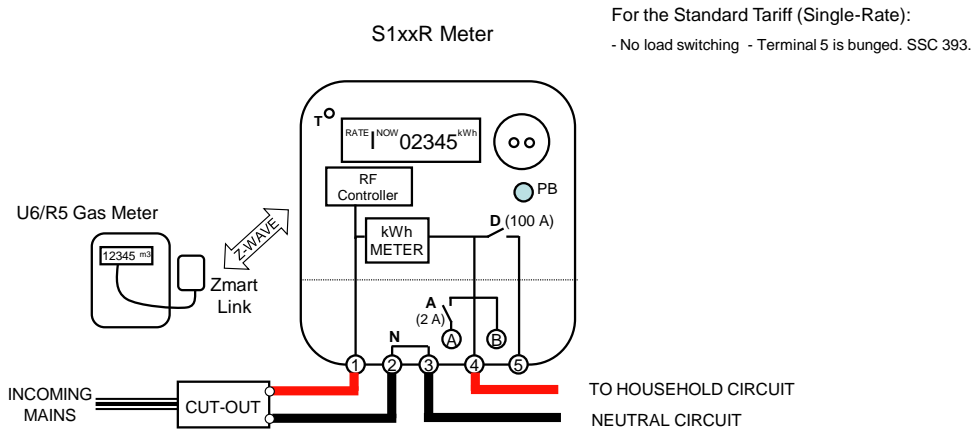

S1xxR BL 2Dec09

S1xxR Meter – no Switched Load (C1)

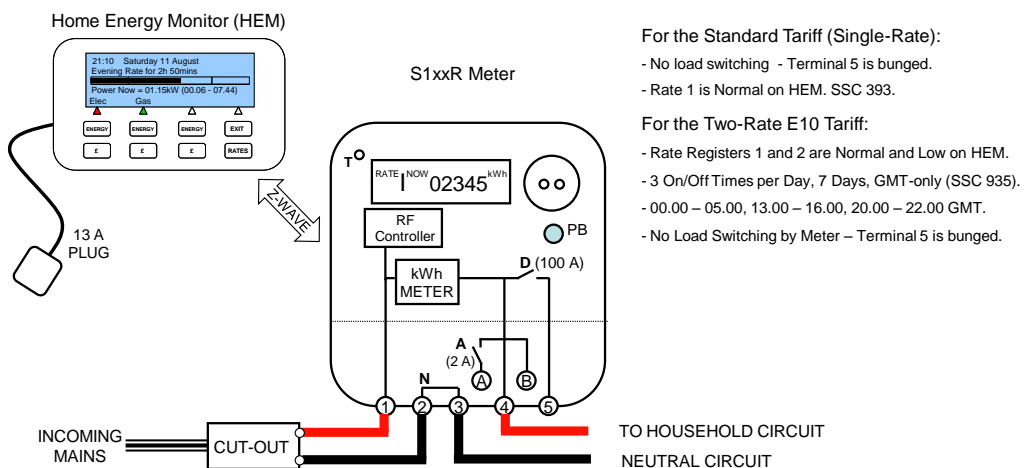

S1xxR BL 2Dec09

S1xxR Meter – with Switched Load (C2)

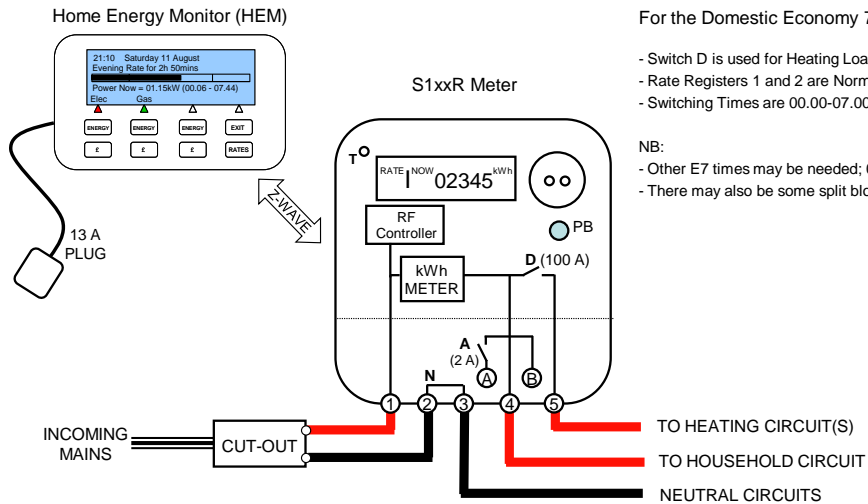

S1xxR BL 2Dec09

For the Domestic Economy 7h Tariff:

- Switch D is used for Heating Loads..
- Rate Registers 1 and 2 are Normal and Low on HEM.
- Switching Times are 00.00-07.00, 7 days, GMT (SSC 244).

NB:

- Other E7 times may be needed; 01.00 – 08.00 (SSC 153).
- There may also be some split block E7 tariffs (SSC 373).

S1xxR Meter – with HEM and Gas Meter (D)

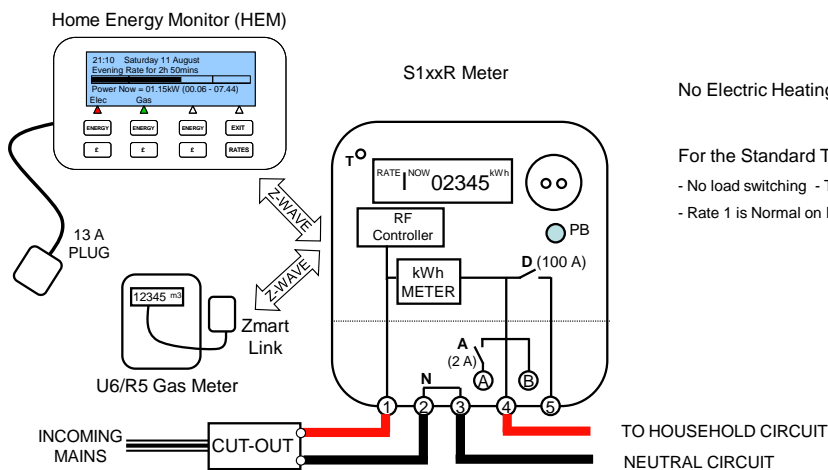

S1xxR BL 2Dec09

No Electric Heating in these Premises.

For the Standard Tariff (Single-Rate):

- No load switching - Terminal 5 is bunged.
- Rate 1 is Normal on HEM. SSC 393 GMT.

ANNEX B - Meter Display Sequences

Installer Mode and Normal Mode (Installer Mode is 5 minutes for S1xxR):

Meter Power Up : into **Installer Mode** for First 5 Minutes:

- a) Load Switch Exercise Mode – Switches D and A
 - b) Installer Display List – with additional functionality for Z-wave
- Note: Hold button down for 2 to 5 s to alternate between (a) and (b)

After First 5 Minutes : Meter is in **Normal Mode**:

- a) Normal Display List applies – push to step through list
- b) After Time-out of 1 Minute it reverts to “RATE NOW” display
- c) No other pushbutton action available in Normal Mode

S1xxR Displays BL
2Dec09

Display Representation

Current Register	RATE NOW kWh
Watts	P 000750
Display Test	[All segments]
Time	TIME
Date	DATE
Rate 1	RATE (NOW) kWh
Rate 2	RATE (NOW) kWh
Rate 3	RATE (NOW) kWh
Rate 4	RATE (NOW) kWh
Import Total	TOTAL kWh
Export Total	TOTAL ← kWh
Tariff Reference	rEF 393
Tariff Change Date	t
Zwave Include	Inc Node
Zwave Exclude	dEL Node
Zwave NIF	nEt

S1xxR Displays BL
2Dec09

◁ End of List ▷

2



INSTALLER List

Current Register
 Display Test
 Time
 Date
 Rate 1
 Rate 2
 Rate 3
 Rate 4
 Import Total
 Export Total
 Tariff Reference
 Tariff Change Date
 Zwave Include
 Zwave Exclude
 Zwave nEt
 < End of List >

NORMAL List – 1R

Current Register
 Watts
 Display Test
 Time
 Date
 Rate 1
 Tariff Reference
 < End of List >

NORMAL List – 2R

Current Register
 Watts
 Display Test
 Time
 Date
 Rate 1
 Rate 2
 Import Total
 Tariff Reference
 < End of List >

NORMAL List – 4R

Current Register
 Watts
 Display Test
 Time
 Date
 Rate 1
 Rate 2
 Rate 3
 Rate 4
 Import Total
 Tariff Reference
 < End of List >

Display Sequences for S1xxR Meters (with Z-wave)

S1xxR Displays BL
 2Dec09

ANNEX C – Home Energy Monitor Displays

(See Annex D for an Overview of the HEM)

Home Energy Monitor – Main Display

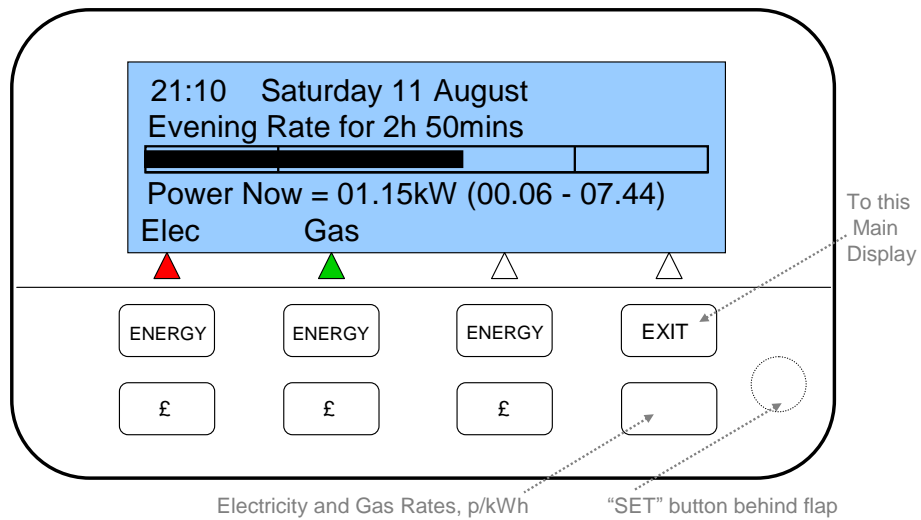

HEM Main BL
7Sep07

1

Home Energy Monitor – Setting Mode

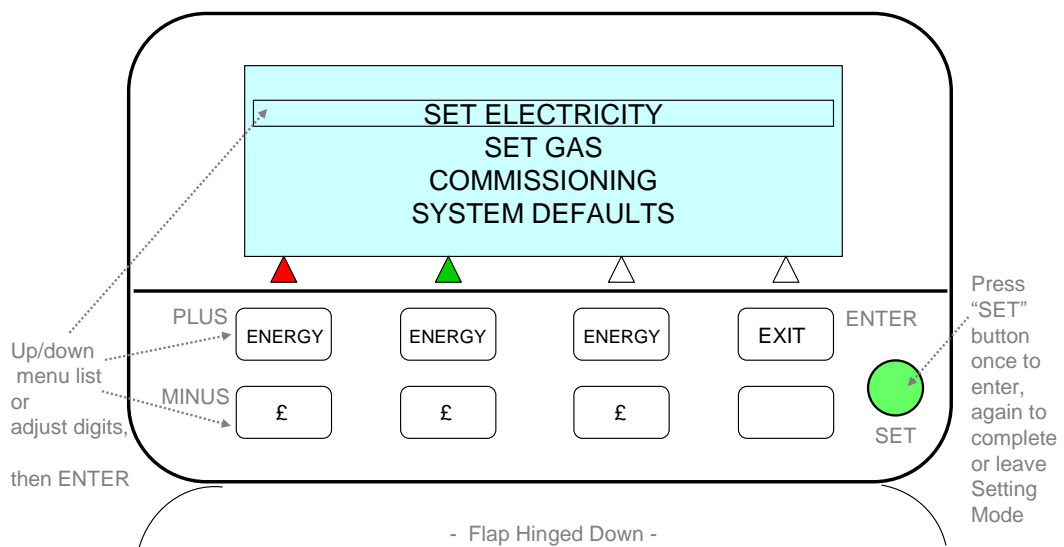

HEM Main BL
7Sep07

2

SETTING THE ELECTRICITY AND GAS PRICES (pence/kWh)

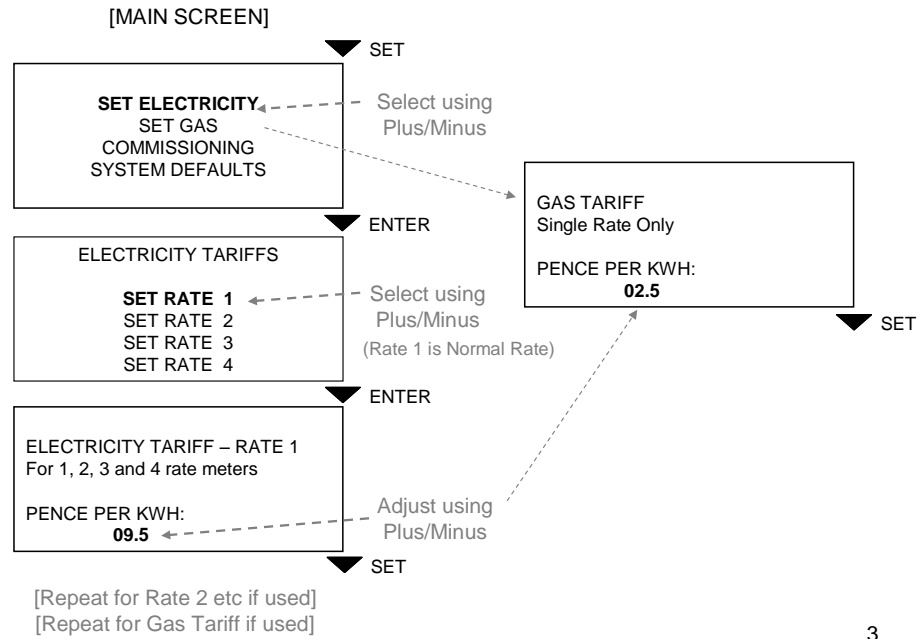

3

COMMISSIONING THE HEM

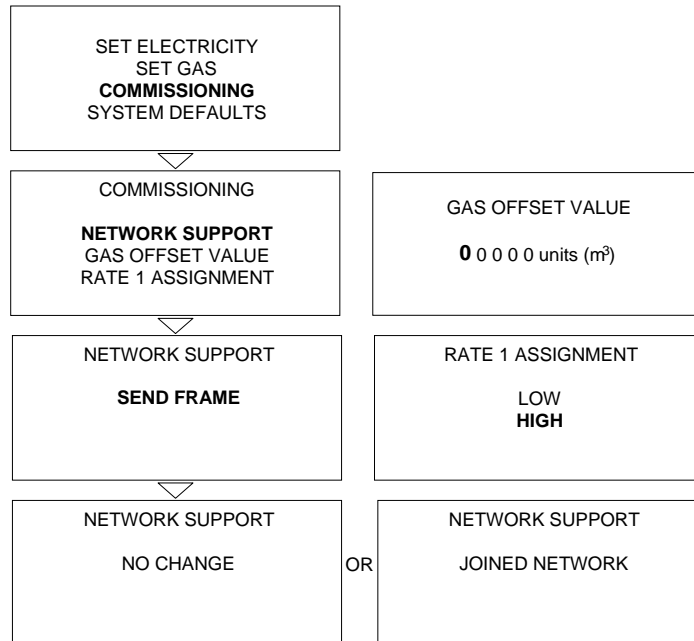

4

SELECTING THE ELECTRICITY DISPLAY MODE

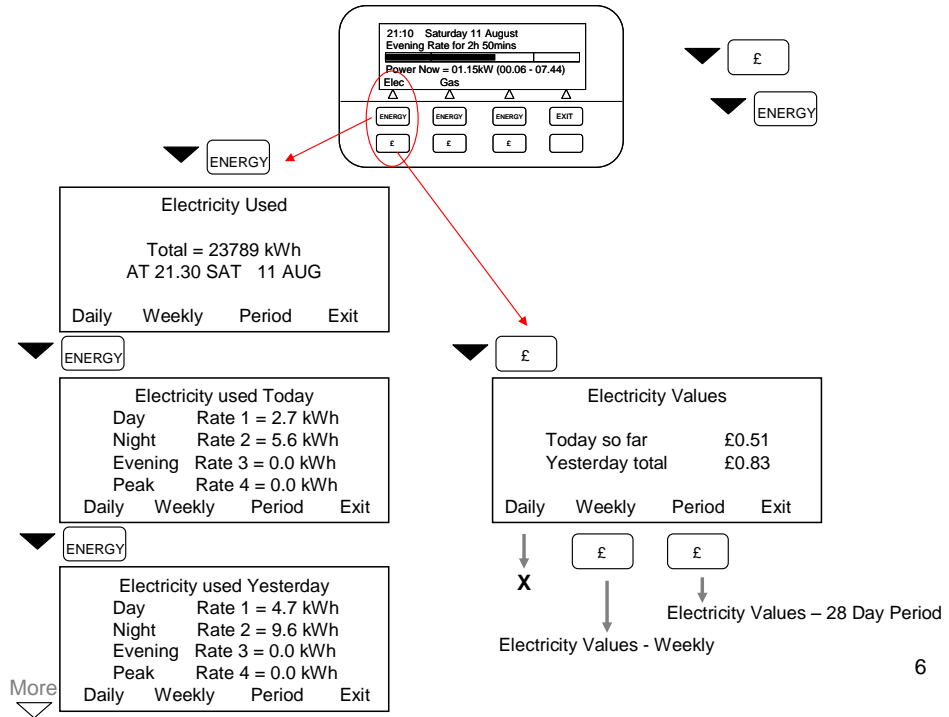

SELECTING THE GAS DISPLAY MODE – If Gas Metering is Included

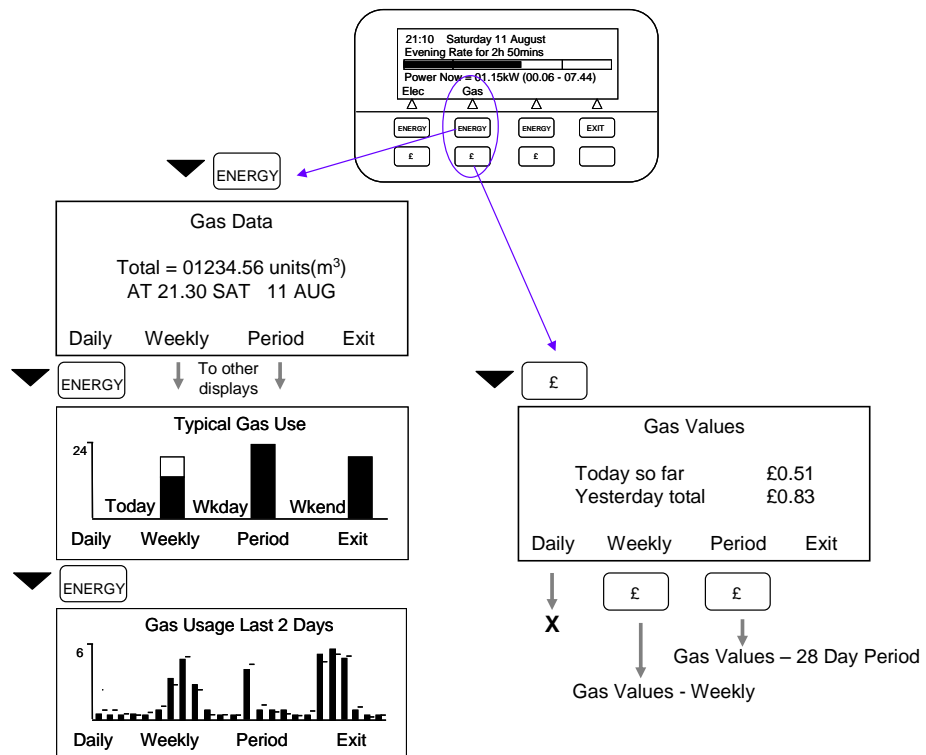

EXAMPLES OF ELECTRICITY AND GAS TEXT DISPLAYS

<p style="text-align: center;">Electricity used Today</p> <p>Normal Rate 1 = 2.7 kWh Low Rate 2 = 5.6 kWh</p> <p style="text-align: center;">Daily Weekly Period Exit</p>	<p style="text-align: center;">Electricity - Weekly</p> <p>This Week so far 002.0kWh Last Week total 016.0kWh</p> <p style="text-align: center;">Daily Weekly Period Exit</p>	<p style="text-align: center;">Electricity Values – Weekly</p> <p>This Week so far £1.51 Last Week total £2.83</p> <p style="text-align: center;">Daily Weekly Period Exit</p>
<p style="text-align: center;">Electricity used Yesterday</p> <p>Normal Rate 1 = 4.7 kWh Low Rate 2 = 9.6 kWh</p> <p style="text-align: center;">Daily Weekly Period Exit</p>	<p style="text-align: center;">Electricity – 28 Day Period</p> <p>Period so far 0138kWh Last Period 0187kWh</p> <p style="text-align: center;">Daily Weekly Period Exit</p>	<p style="text-align: center;">Electricity Values – 28 Day Period</p> <p>This Period so far £0.51 Last Period total £0.83</p> <p style="text-align: center;">Daily Weekly Period Exit</p>
<p style="text-align: center;">Gas Data</p> <p>Total = 00000.00 units(m³) TIME STAMP NOT AVAILABLE</p> <p style="text-align: center;">Daily Weekly Period Exit</p> <p style="text-align: center; font-size: small;">↑ If no gas unit is fitted, or no communication with gas unit</p>	<p style="text-align: center;">Gas - Weekly</p> <p>This Week so far 054.0 units Last Week total 085.0 units</p> <p style="text-align: center;">Daily Weekly Period Exit</p>	<p style="text-align: center;">Gas Values – Weekly</p> <p>This Week so far £1.51 Last Week total £2.83</p> <p style="text-align: center;">Daily Weekly Period Exit</p>
	<p style="text-align: center;">Gas – 28 Day Period</p> <p>Period so far 0140 units Last Period 0185 units</p> <p style="text-align: center;">Daily Weekly Period Exit</p>	<p style="text-align: center;">Gas Values – 28 Day Period</p> <p>This Period so far £0.51 Last Period total £0.83</p> <p style="text-align: center;">Daily Weekly Period Exit</p>

EXAMPLES OF ELECTRICITY AND GAS CHART DISPLAYS

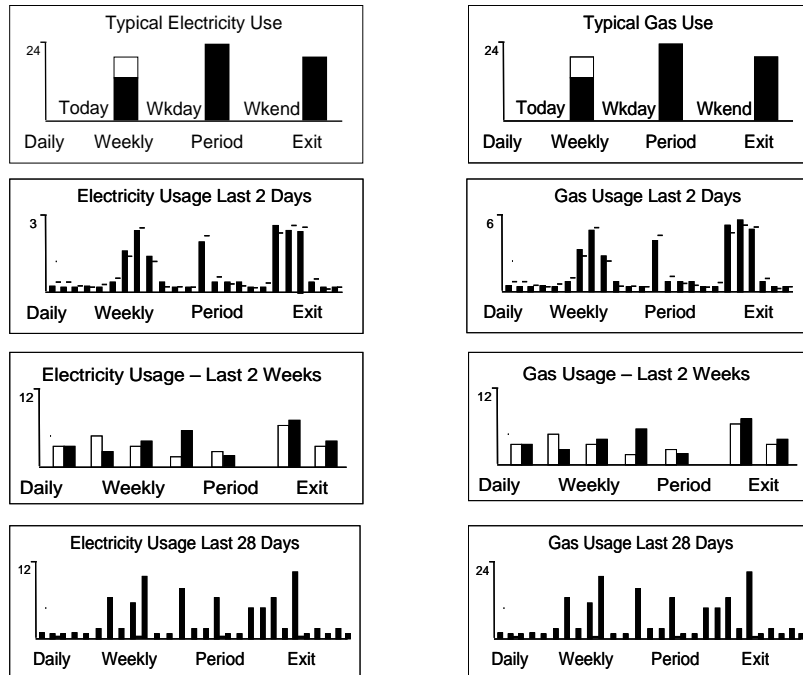

ANNEX D – Overview of the Home Energy Monitor

The HEM is used with configurations C and D. The HEM is plugged into a 13 A socket in a convenient location (e.g. kitchen, hall, lounge) and should remain plugged in at all times after commissioning – a red notice to this effect is included on the plug cover. The HEM should be placed in a location where it can regularly be seen, but will not get in the way of daily activities. If the HEM has to be unplugged or repositioned for any reason it should only be unplugged for short periods of time (a few minutes). The HEM is provided with a mains cable 1.1 m long.

The HEM must be included into the S1xxR meter's local Z-wave network during commissioning. Where gas data is also to be available on the HEM the Zmart Link unit must also be included into the S1xxR's network.

The HEMs are delivered without any site-specific parameters loaded. The HEM picks up the tariff structure and times from the associated S1xxR meter. The electricity (and gas) prices/rates are to be set on the HEM during the installation visit. The maximum price setting for the electricity and gas rates is 25.5 p/kWh, in increments of 0.1 p/kWh. The rate names Normal/Low are displayed on the HEM if the meter has a 1-rate or 2-rate tariff configuration, while any 3- or 4-rate tariff in the meter results in the rate names Day, Night, Evening, and Peak being displayed on the HEM. Annex C gives display examples.

The HEM uses the prices/rates set into it to calculate the cost of the energy used over the previous and current day, week, and rolling 28-day period. The energy values are stored in the HEM and when their £ values are requested they are calculated from the prices/rates that are currently set in the HEM. Changing the price settings means that the new prices/rates will be used on the stored energy values when new £ values are requested and they will be displayed for the recent days, weeks, and the rolling 28-day period. The HEM does not allow for standing charges or block-type tariffs when indicating the £ values of the various energy values consumed. The £ values indicated are shown on the same basis as the price/rate settings that are entered – so this may be with or without any dual-fuel discount, with or without any direct debit discount, and with or without 5% VAT on domestic energy supplies. (The prices printed on customers' bills are often expressed WITH any dual-fuel discount, WITHOUT any direct debit discount, and WITHOUT 5% VAT added).

In normal operation the two red/orange/green consumption indicators light when the HEM is showing its main display, according to the following rules (the left indicator is for electricity, the other is for gas usage):

- Green: Today's usage so far is less than 90% of yesterday's (or yesterday was zero).
- Amber: Today's usage so far is between 90% and 110% of yesterday's consumption.
- Red: Today's usage so far is above 110% of yesterday's consumption.

The indicators may show any of these colours – red does not mean the HEM is faulty.

If the HEM has not received any meter data for 3 minutes then "NO COMMS" is shown on the main screen instead of "Power Now" – this reverts to normal (Power Now) as soon as a successful 15-second update is received from the meter. The wireless transmissions to the HEM are at a very low power level (a milliwatt).

ANNEX E – Signal Strength Survey for S1xxR Meters

E1 General

When a home is to have an S1xxR meter installed along with a HEM Energy Monitor and/or a Zmart Link gas unit then a short survey is first needed to ensure that satisfactory wireless operation at 868 MHz can be achieved for each of the two radio paths: S1xxR to HEM, and S1xxR to Zmart Link. If the survey results are acceptable then installation of the smart metering equipment can go ahead as in chapters 7 to 9 of the instructions.

The basic method uses an SG23R or S1xxR battery-powered test transmitter and a hand held RF signal strength meter, operating at 868 MHz. The test transmitter is temporarily placed or fixed close to the electricity meter position and switched on, then the RF signal strength meter is taken to the gas meter position and/or the place proposed for the HEM Energy Monitor to check for adequate signal strength at each of those locations.

E2 Checking the Gas Meter Location

For Configurations B and D where the gas meter is to be fitted with a Zmart Link gas unit then the potential location area for the Zmart Link unit is also effectively predetermined. Although the Zmart Link is fitted with a 2 m cable for connection to the gas meter pulse output, in domestic premises it is unlikely that the unit (with its internal antenna) can be located much more than 30 cm away from the gas meter, for various practical reasons. This may limit the scope for finding a location with sufficient signal strength for the Zmart Link unit in some premises.

Check the RF signal strength by taking the RF meter to the gas meter location, which will involve one of the four types of layout in (a) to (d) below. The RF meter is held vertically at arm's length in each potential fitting location and the signal strength noted as acceptable or not for the Zmart – 3 or 4 amber LEDs should be lit. The potential positions for fixing the Zmart Link near conventional gas meters are:

- a) External gas meter cabinet, surface mounted: Velcro to upper left or right sidewall.
- b) External gas meter cabinet, flush mounted: Velcro to upper left rear wall, or hang from flexible inlet pipe.
- c) Internal wall-mounted gas meter location, higher up: hang from flexible inlet pipe.
- d) Internal floor-mounted gas meter location: fix to gas pipe 30 cm above meter if practical.

Evaluation of results: There may be some premises where the electricity meter and gas meter positions are either too far apart for successful wireless operation or the path between them involves several walls or a thick external stone wall or an external corner. Large white goods in the direct path may also reduce signal coverage. Where the gas meter is on a solid concrete floor it may not be practical to mount the Zmart Link unit (with its internal antenna) at an adequate height for good communications. In such cases the signal strength near the gas meter may not be sufficient and a decision will need to be taken to exclude the Zmart Link and gas data from this installation.

Note 1: The Zmart Link gas unit itself is not intended for outdoor use without an enclosure.

Note 2: Use of the Zmart Link with semi-concealed gas meters is not anticipated.

E3 Checking the HEM Energy Monitor Location

For Configurations C and D where a HEM is to be installed then a permanent indoor location (convenient for the customer) must be found and checked for sufficient signal strength – using the SG23R or S1xxR test transmitter at the electricity meter position. It may also simplify the commissioning process if a temporary location for the HEM that is convenient for the meter operator can first be found and checked – e.g. where the S1xxR meter is installed in a garage the HEM might also be used temporarily in the garage for commissioning, then moved to the permanent location for the final checks.

For Configuration B (with Zmart Link gas but no HEM permanently installed) a temporary location for a “Test” HEM that is convenient for the meter operator should also be found and checked (e.g. a socket near an indoor electricity meter, or in the hall or utility room).

The permanent location for the HEM must be chosen to give satisfactory signal reception – this should normally be within 6 m (20 feet) horizontally and 4 m (13 feet) vertically of the electricity meter position. Where a property has thick stone walls and the electricity meter is in an outdoor meter box any possible HEM locations are likely to be found on the inside near to the electricity meter position.

In addition to ensuring that satisfactory signal reception is obtained the following practical points need to be considered when selecting a suitable permanent location for the Home Energy Monitor:

- On a desk or work surface (not at low level – keep away from small children).
- Where it is easily accessible frequently, but is unlikely to be dislodged or dropped.
- Away from pouring water or steam – taps, sinks, kettles.
- Not likely to be in direct sunlight for lengthy periods or close to strong sources of heat.
- Not covered up at all, nor in a cupboard or drawer...
- Not on vibrating equipment (washing machines, spin dryers, microwave ovens).
- The HEM must be able to remain plugged into its own 13 A socket at all times.

Check the potential HEM location(s) by taking the RF meter to them and measure the RF signal strength with the SG23R or S1xxR test transmitter in position and switched on; both the permanent and the temporary locations should be checked in turn. The RF meter is held vertically at arm’s length at each potential location and the signal strength then noted as acceptable or not for the HEM – all 4 amber LEDs should be lit in suitable locations.

Evaluation of results: Try to avoid choosing a location for the HEM where users must place themselves between the unit and the electricity meter when operating the HEM – the RF meter may give varying results in such situations. Also try to avoid locations where thick solid walls and large white goods are in the direct line between the electricity meter and the HEM. There may be limited or no scope for finding a practical location with sufficient signal strength for the HEM in some premises. In this case the HEM should not remain on site, but if the Zmart Link gas unit has been installed satisfactorily then the site may be left logging gas and electricity data after excluding the HEM and removing it from the premises.

ANNEX F – Advanced Functions for Z-Wave Certified Meter

This section is for advanced use of z-wave functions only, such as installing the system on another Z-wave network within the property.

F1 – Learn Mode

With the meter in installer mode the following procedure needs to be carried out with the third party controller in network include mode to add the meter to its network.

With the meter in installer mode the following procedure needs to be carried out with the third party controller in network exclude mode to remove the meter from its network.

1. Press and hold the blue button for 2 seconds (enters Installer Displays).
2. Cycle through each menu display item with single presses until the display shows “LEArn”. Do not press the blue button again unless repeating the process.
3. Wait 10s and the display will show “oooo” for one second.
4. Display will now show either “SENT” or “FAIL” (if “FAIL” wait for 30s and retry from point 2). Note if it is still not possible to obtain the “SENT” message then the meter should be powered down briefly and powered up again.

On entering this mode there is a 2 minute window to do the include or exclude process. The success of the action is indicated by a brief “PASS” or “FAIL” message on the meter’s display. A timeout will be indicated by a brief “FAIL” message.

F2 – Association and Disassociation of HEM and ZMART

If the certified meter, HEM and ZMART have been included on to another controller’s network then by following the procedures for including HEM and ZMART, in section 9, it will be possible for the entire system to function on that network. The HEM and ZMART will be associated to the meter.

The HEM and ZMART can be disassociated by following the exclude procedures in sections 12 and 13.

Horstmann Group Limited
Roman Farm Road
Bristol
BS4 1UP

Tel: 0117 978 8700

Fax: 0117 978 8701

E-mail: sales@horstmann.co.uk

Web: www.horstmann.co.uk