



WISEZD2102-5 Door- and Window Sensor Gen 5

Firmware Version : 5.1



Quick Start

S This device is a wireless Z-Wave sensor. A single click on the tampering switch inside the enclosure will confirm Inclusion and Exclusion. Releasing the tampering switch will wake up the device and keep it awake.

Please refer to the chapters below for detailed information about all aspects of the products usage.

What is Z-Wave?

This device is equipped with wireless communication complying to the Z-Wave standard. Z-Wave is the **international standard for wireless communication** in smart homes and buildings. It is using the **frequency of 868.42 MHz** to realize a very stable and secure communication. Each message is reconfirmed (**two-way communication**) and every mains powered node can act as a repeater for other nodes (**meshed network**) in case the receiver is not in direct wireless range of the transmitter.

Z-Wave differentiates between Controllers and Slaves. Slaves are either sensors (**S**) transmitting metered or measured data or actuators (**A**) capable to execute an action. Controllers are either static mains powered controllers (**C**) also referred to as gateways or mobile battery operated remote controls(**R**). This results in a number of possible communication patterns within a Z-Wave network that are partly or completely supported by a specific device.

1. Controllers control actuators
2. Actuators report change of status back to controller
3. Sensors report change of status of measured values to controller
4. Sensors directly control actuators
5. Actuators control other actuators
6. Remote controls send signals to static controllers to trigger scenes or other actions
7. Remote controls control other actuators.

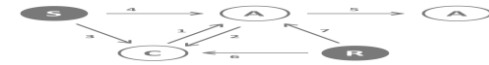

There are two different role a controller can have. There is always one single primary controller that is managing the network and including/excluding devices. The controller may have other functions - like control buttons - as well. All other controllers don't manage the network itself but can control other devices. They are called secondary controllers. The image also shows that its not possible to operate a sensor just from a remote control. Sensors only communicate with static controllers.

Product description

This sensor offers information whether a door or window is open or closed. The product consists of a magnetic element and the main unit. One of the parts is mounted on the moving part of the window or of the door. The other part is placed on the frame. The installation can be done with screws or double-sided tape. The device is battery-operated and therefore in sleeping mode unless an action is detected. After a programmable sleeping time the device wakes up and sends a status information. After this the unit goes back to sleeping modus. Batteries can be changed without unscrewing the device from the door or frame. The unit will give a visual warning on the device and sends a warning to the Z-Wave controller, when batteries need to be replaced. The units send information to a controller or any other associated Z-Wave device. Up to 5 devices can be controlled from this device. Two terminals allows to connection of an external dry contact in parallel to the magnetic contact. A tamper switch protects the device from removal or manipulation if used in security applications. The powerful CR123 Lithium battery lasts 3...5 years n normal operation conditions. The device supports normal Z-Wave inclusion, auto inclusion and network wide inclusion for convenient handling. Scope of delivers includes the device itself, the bracket for the magnet and the magnet itself, the battery, adhesive tape and an instruction manual. The device will then send all commands as secure commands unless the receiving device can not accept them. Then the command is send the normal way automatically.

Batteries

The unit is operated by batteries. Use only batteries of correct type. Never mix old and new batteries in the same device. Used batteries contain hazardous substances and should not be disposed of with household waste!

Battery Type: 1 * CR123A

Installation Guidelines

1. Unscrew the screw fastening on the cover and slide the cover down.
2. Insert the CR123A battery into the batter compartment and the LED will start to flash slowly. This means that the sensor is not yet included into a Z-Wave network.

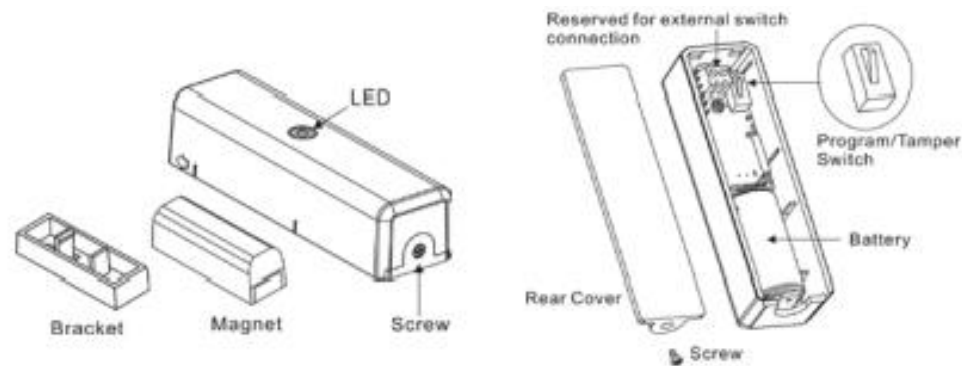

3. Use the screws or adhesive tape to fix the cover on the frame along the opening edge of the door or window. See figure below.

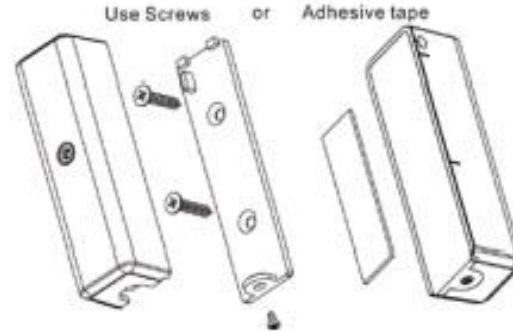

Behavior within the Z-Wave network

On factory default the device does not belong to any Z-Wave network. The device needs to join an existing wireless network to communicate with the devices of this network. This process is called **Inclusion**. Devices can also leave a network. This process is called **Exclusion**. Both processes are initiated by the primary controller of the Z-Wave network. This controller will be turned into exclusion or inclusion mode. Please refer to your primary controllers manual on how to turn your controller into inclusion or exclusion mode. Only if the primary controller is in inclusion or exclusion mode, this device can join or leave the network. Leaving the network - i.e. being excluded - sets the device back to factory default.

If the device already belongs to a network, follow the exclusion process before including it in your network. Otherwise inclusion of this device will fail. If the controller being included was a primary controller, it has to be reset first.

A single click for one second on the tampering switch inside the enclosure will confirm Inclusion and Exclusion.

Operating the device

Whenever the door or the window where the sensor is mounted will open or close the device will send out a wireless signal.

Wakeup Intervals - how to communicate with the device?

W This device is battery operated and turned into deep sleep state most of the time to save battery life time. Communication with the device is limited. In order to communicate with the device, a static controller **C** is needed in the network. This controller will maintain a mailbox for the battery operated devices and store commands that can not be received during deep sleep state. Without such a controller, communication may become impossible and/or the battery life time is significantly decreased.

This device will wakeup regularly and announce the wakeup state by sending out a so called Wakeup Notification. The controller can then empty the mailbox. Therefore, the device needs to be configured with the desired wakeup interval and the node ID of the controller. If the device was included by a static controller this controller will usually perform all necessary configurations. The wakeup interval is a tradeoff between maximal battery life time and the desired responses of the device.

It will be triggering after opening the rear cover, also the red LED will keep on lasting 10 seconds and ZD2102 will send "Wake UP Notification" after 10 seconds. If ZD2102 received "Wake Up No More Information" command then the red LED will go off or it will wait 10 seconds then go off. It will proceed all the commands after sending the "Wake Up Notification".

It is possible to set the node ID to 255 to send wakeup notifications as broadcast. In this mode device takes more time to go to sleep and drains battery faster, but can notify all it's direct neighbors about a wakeup.

Node Information Frame

NI The Node Information Frame is the business card of a Z-Wave device. It contains information about the device type and the technical capabilities. The inclusion and exclusion of the device is confirmed by sending out a Node Information Frame. Beside this it may be needed for certain network operations to send out a Node Information Frame.

A single click on the tampering switch inside the enclosure will send out a Node Information Frame.

Associations

A Z-Wave devices control other Z-Wave devices. The relationship between one device controlling another device is called *association*. In order to control a different device, the controlling device needs to maintain a list of devices that will receive controlling commands. These

lists are called **association groups** and they are always related to certain events (e.g. button pressed, sensor triggers, ...). In case the event happens all devices stored in the respective association group will receive a common wireless command.

Association Groups:

1	All triggering reports & low voltage report will be sent to the associated nodes. (max. nodes in group: 5)
---	--

Configuration Parameters

Z-Wave products are supposed to work out of the box after inclusion, however certain configuration can adapt the function better to user needs or unlock further enhanced features.

IMPORTANT: Controllers may only allow to configure signed values. In order to set values in the range 128 ... 255 the value sent in the application shall be the desired value minus 256. For example: to set a parameter to 200 it may be needed to set a value of 200 minus 256 = minus 56. In case of two byte value the same logic applies: Values greater than 32768 may needed to be given as negative values too.

External Switch (Parameter Number 1, Parameter Size 1) The parameter defines if an external switch is disabled/enabled.

Value	Description
0	External Switch is disabled. (Default)
255	External Switch is enabled.

Command Classes

Supported Command Classes

- Z-Wave Plus Information (version 2)
- Version (version 2)
- Manufacturer Specific (version 2)
- Device Reset Locally (version 1)

- Association (version 2)
- Association Group Information (version 1)
- Powerlevel (version 1)
- Battery (version 1)
- Alarm (version 4)
- Configuration (version 1)
- Wake Up (version 2)
- Firmware Update Meta Data (version 2)
- Basic (version 1)

Controlled Command Classes

- Basic (version 1)

Technical Data

IP Rating	20
Battery Type	1 * CR123A
Explorer Frame Support	No
SDK	
Device Type	Slave with routing capabilities
Generic Device Class	
Specific Device Class	
Routing	No
FLiRS	No

Explanation of Z-Wave specific terms

- **Controller** — is a Z-Wave device with capabilities to manage the network. Controllers are typically Gateways, Remote Controls or battery operated wall controllers.
- **Slave** — is a Z-Wave device without capabilities to manage the network. Slaves can be sensors, actuators and even remote controls.
- **Primary Controller** — is the central organizer of the network. It must be a controller. There can be only one primary controller in a Z-Wave network.
- **Inclusion** — is the process of bringing new Z-Wave devices into a network.
- **Exclusion** — is the process of removing Z-Wave devices from the network.
- **Association** — is a control relationship between a controlling device and a controlled device.
- **Wakeup Notification** — is a special wireless message issued by a Z-Wave device to announce that it is able to communicate.
- **Node Information Frame** — is a special wireless message issued by a Z-Wave device to announce its capabilities and functions.

Disposal Guidelines

The product contains batteries. Please remove the batteries when the device is not used.

Do not dispose of electrical appliances as unsorted municipal waste, use separate collection facilities. Contact your local government for information regarding the collection systems available. If electrical appliances are disposed of in landfills or dumps, hazardous substances can leak into the groundwater and get into the food chain, damaging your health and well-being.