



MCO_TPS411

Z-Wave Glass surface touch panel switch

Firmware Version : 1.0



Quick Start

A This device is a Z-Wave Actuator. To include or exclude the device you only need to press and hold any key for 3 seconds.

Please refer to the chapters below for detailed information about all aspects of the products usage.

What is Z-Wave?

This device is equipped with wireless communication complying to the Z-Wave standard. Z-Wave is the **international standard for wireless communication** in smart homes and buildings. It is using the **frequency of 868.42 MHz** to realize a very stable and secure communication. Each message is reconfirmed (**two-way communication**) and every mains powered node can act as a repeater for other nodes (**meshed network**) in case the receiver is not in direct wireless range of the transmitter.

Z-Wave differentiates between Controllers and Slaves. Slaves are either sensors (**S**) transmitting metered or measured data or actuators (**A**) capable to execute an action. Controllers are either static mains powered controllers (**C**) also referred to as gateways or mobile battery operated remote controls (**R**). This results in a number of possible communication patterns within a Z-Wave network that are partly or completely supported by a specific device.

1. Controllers control actuators
2. Actuators report change of status back to controller
3. Sensors report change of status of measured values to controller
4. Sensors directly control actuators
5. Actuators control other actuators
6. Remote controls send signals to static controllers to trigger scenes or other actions
7. Remote controls control other actuators.

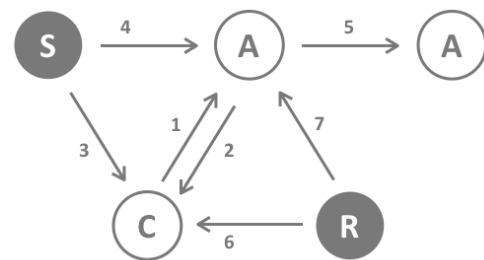

There are two different role a controller can have. There is always one single primary controller that is managing the network and including/excluding devices. The controller may have other functions - like control buttons - as well. All other controllers don't manage the network itself but can control other devices. They are called secondary controllers. The image also shows that its not possible to operate a sensor just from a remote control. Sensors only communicate with static controllers.

Product description

The MCO_TPS411 is a glass-surface wireless actuator able to to switch a load up to 1100 W. It is designed for application in UK Pattress boxes (according to British Standard). Beside local switching the device can be used to control two groups of directly associated devices or scenes stored in the central controller. A blue LED on every button indicates the switching status. The installation of the device requires a 3 wire system with neutral wire.

Before Device is installed

Please read carefully the enclosed user manual before installation of the radio-actuator, in order to ensure an error-free functioning.

ATTENTION: only authorized technicians under consideration of the country-specific installation guidelines/norms may do works with 230 Volt mains power. Prior to the assembly of the product, the voltage network has to be switched off and ensured against re-switching.

The product is permitted only for proper use as specified in the user manual. Any kind of guarantee claim has to be forfeited if changes, modifications or painting are undertaken. The product must be checked for damages immediately after unpacking. In the case of damages, the product must not be operated in any case. If a danger-free operation of the equipment cannot be assured, the voltage supply has to be interrupted immediately and the equipment has to be protected from unintended operation.

Installation Guidelines

Important: Please make sure you have cut off power supply before you start to install the device.

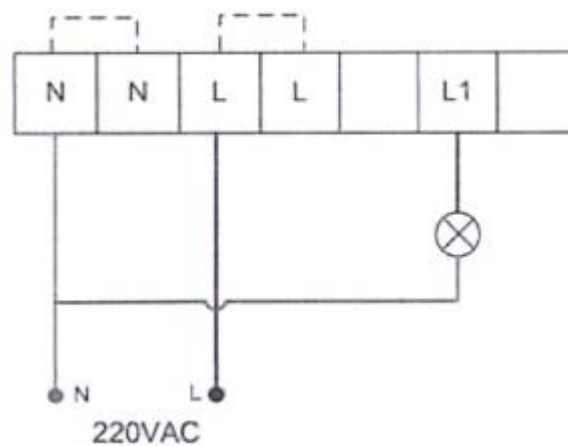

- Connect Hot Line to 'L'
- Connect Neutral Line to 'N'
- Connect Load wire to 'L1'

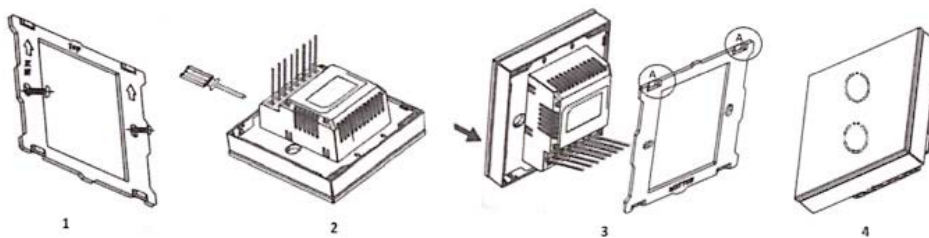

1. Remove the steel frame from the device, and secure it onto the junction box with two screws.
2. Insert all wires into the right terminals and tighten screws.
3. Attach the wired device on 'A' points of the steel frame as shown first, and then push the whole device into junction box.
4. Confirm the device is well mounted, power on and it is ready to operate.

Behavior within the Z-Wave network

On factory default the device does not belong to any Z-Wave network. The device needs to join an existing wireless network to communicate with the devices of this network. This process is called **Inclusion**. Devices can also leave a network. This process is called **Exclusion**. Both processes are initiated by the primary controller of the Z-Wave network. This controller will be turned into exclusion respective inclusion mode. Please refer to your primary controller's manual on how to turn your controller into inclusion or exclusion mode. Only if the primary controller is in inclusion or exclusion mode, this device can join or leave the network. Leaving the network - i.e.

being excluded - sets the device back to factory default.

If the device already belongs to a network, follow the exclusion process before including it in your network. Otherwise inclusion of this device will fail. If the controller being included was a primary controller, it has to be reset first.

To include or exclude the device you only need to press and hold any key for 3 seconds.

Operating the device

The actuator is operated by the local switching Touch panels or wirelessly using Z-Wave commands.

Associations

A Z-Wave devices control other Z-Wave devices. The relationship between one device controlling another device is called *association*. In order to control a different device, the controlling device needs to maintain a list of devices that will receive controlling commands. These lists are called **association groups** and they are always related to certain events (e.g. button pressed, sensor triggers, ...). In case the event happens all devices stored in the respective association group will receive a common wireless command.

Association Groups:

- 1 Switch Button Group 1 (max. nodes in group: 5)
- 2 Switch Button Group 2 (max. nodes in group: 5)
- 3 all Status Reports (max. nodes in group: 1)

Command Classes

Supported Command Classes

- Binary Switch (version 1)
- All Switch (version 1)
- Multi Channel (version 3)
- Manufacturer Specific (version 1)
- Association (version 1)
- Version (version 1)
- Multi Channel Association (version 2)
- Basic (version 1)

Controlled Command Classes

- Multi Channel (version 3)
- Basic (version 1)

Technical Data

Power Supply	220V 50 Hz
Attachable Loads	up to 1100 W on 220V with 5A each channel
Explorer Frame Support	Yes
SDK	4.55.00
Device Type	Slave with routing capabilities
Generic Device Class	Binary Switch
Specific Device Class	Binary Power Switch
Routing	Yes

FLiRS	No
Firmware Version	1.0

Explanation of Z-Wave specific terms

- **Controller** — is a Z-Wave device with capabilities to manage the network. Controllers are typically Gateways, Remote Controls or battery operated wall controllers.
- **Slave** — is a Z-Wave device without capabilities to manage the network. Slaves can be sensors, actuators and even remote controls.
- **Primary Controller** — is the central organizer of the network. It must be a controller. There can be only one primary controller in a Z-Wave network.
- **Inclusion** — is the process of bringing new Z-Wave devices into a network.
- **Exclusion** — is the process of removing Z-Wave devices from the network.
- **Association** — is a control relationship between a controlling device and a controlled device.
- **Wakeup Notification** — is a special wireless message issued by a Z-Wave device to announce that it is able to communicate.
- **Node Information Frame** — is a special wireless message issued by a Z-Wave device to announce its capabilities and functions.

Disposal Guidelines

The product does not contain hazardous chemicals.

Do not dispose of electrical appliances as unsorted municipal waste, use separate collection facilities. Contact your local government for information regarding the collection systems available. If electrical appliances are disposed of in landfills or dumps, hazardous substances can leak into the groundwater and get into the food chain, damaging your health and well-being.